

MY25 

ENDURO RANGE LAUNCH



SHERCO

► INDEX

- 3** THE COMPANY
- 7** RANGE OF PRODUCTS
- 16** AFTERSALES
- 25** PROMOTION
- 28** RACING
- 40** NEW RANGE
- 83** PARTNERS



SHERCO

SHERCO

**COMPANY
PRESENTATION**



HISTORY

SHERCO is a French company, the leading motorbike manufacturer in France. The company was created in 1998 by Marc Teissier and Andreu Codina, both former trial riders. The head office and the motorbike production unit are located in Nîmes (30). SHERCO manufactures Trial and Enduro bikes. It is currently a range of more than 20 vehicles and 15,000 motorbikes are currently produced each year on the Gard site. The company is present throughout the world on 5 continents, in more than 86 countries and works with more than 11 00 sales outlets. The company employs over 160 people in France and abroad. It is a team of enthusiasts who work every day with know-how and expertise to write the most beautiful pages of the motorbike. SHERCO is involved in the World Enduro, Extreme Enduro, Rally Raid and Trial championships. Since 1998, it has already won more than 10 world championship titles in all categories. And the adventure is not about to end there!



SHERCO

SHERCO FACTORY BRIEF

- Date of creation : 1998
- Headquarter and factory in France
- 5 brands (Sherco, Scorpa, HRD, SPES, OXIA)
- 160 employees
- A range of 20 motorcycles
- 86 countries across 5 continents
- 1 100 dealers
- 15 000 motorbikes / year
- 23 000 square meters of buildings :
 - 1 assembly factory
 - 1 gearbox and machining factory
 - 1 competition service building
 - 1 storage building

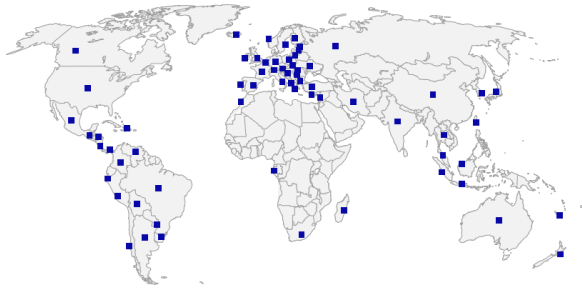

A 25 YEAR HISTORY IN MOTORCYCLE

1998
SHERCO
CREATION

1999
TRIAL
FACTORY
IN SPAIN

2002
HRD
PURCHASING

2003
ENDURO
FACTORY
IN FRANCE

2009
SCORPA
PURCHASING

2017
NEW
ENDURO
FACTORY

2020
TRIAL FACTORY
IN FRANCE

2023
GEARBOX
FACTORY

2024
NEW RACING
DEPARTMENT
BUILDING

CURRENT INFRASTRUCTURES

- 1 Headquarters
Production lines
R&D
- 2 Gearbox machining
Crankcase machining
Cylinder-head machining
Motorbikes logistics
Spares Parts logistics
- 3 Racing Department



- 4 Automation of the spare parts service



SHERCO

**RANGE OF
PRODUCTS**

RANGE OF MOTORCYCLES

20 MODELS

SHERCO'S RANGE OF MOTORCYCLES INCLUDES MORE THAN 20 MODELS IN DIFFERENT SEGMENTS :

- E-BIKE
- MOPED AND 125 4 STROKE
- TRIAL
- LEISURE
- SUPERMOTO
- ENDURO

THE DISPLACEMENT RANGE, FROM 50CC TO 500CC, IS SUITABLE FOR ALL USES FROM OFF-ROAD TO ROAD, FROM COMPETITION TO COMMUTING.



E-BIKE

BIKEN



SHERCO

RANGE OF MOTORCYCLES

MOPED & 125 4 STROKE

FACTORY

- 50 SE-RS Factory
- 50 SE-R Factory
- 50 SM-RS Factory
- 50 SM-R Factory
- 125 SMF Factory
- 125 SEF Factory

BLACKMOON

- 50 SM-R Blackmoon
- 50 SM-RS Blackmoon
- 125 SMF Blackmoon

SILVER

- 50 SM-R Silver
- 50 SM-RS Silver



RANGE OF MOTORCYCLES

TRIAL

- 125 ST Factory
- 250 ST Factory
- 300 ST Factory



RANGE OF MOTORCYCLES

LEISURE

■ 125 TY



SHERCO

RANGE OF MOTORCYCLES

SUPERMOTO

2 STROKE

- 125 SM Factory

4 STROKE

- 500 SMF Factory



RANGE OF MOTORCYCLES

ENDURO

2 STROKE

- 125 SE Factory
- 250 SE Factory
- 300 SE Factory / Racing

4 STROKE

- 250 SEF Factory
- 300 SEF Factory / Racing
- 450 SE Factory
- 500 SE Factory



ENGINES

2T TRIAL



- 125 - 250 - 300 2 Stroke
- Injection
- Kick start
- 16,4 kg

2T ENDURO - SM



- 125 - 2 Stroke
- Carburator
- Electric start
- Electronic powervlve
- 19 kg

2T ENDURO



- 250 - 300 2 Stroke
- Carburator
- Electric start
- Electronic powervlve
- 24,2 kg

4T ENDURO



- 250 - 300 4 Stroke
- Injection
- Electric start
- 24 kg - 24,25 kg

4T ENDURO - SM



- 450 - 500 4 Stroke
- Injection
- Electric start
- 31,2 kg

SHERCO

AFTER SALES

SPARE PARTS DEPARTMENT

- The quantity of references in backorder represent only 0.5 to 2% of the inventory
- New building dedicated to spare parts 3000 square-meters
- Automation of the spare parts store using robots (2024 2025 project)



ENDURO PRO-ELITE GARMENTS



ENDURO PRO-ELITE GARMENTS



ENDURO PRO-LINE GARMENTS



PADDOCK GARMENTS



CASUAL GARMENTS

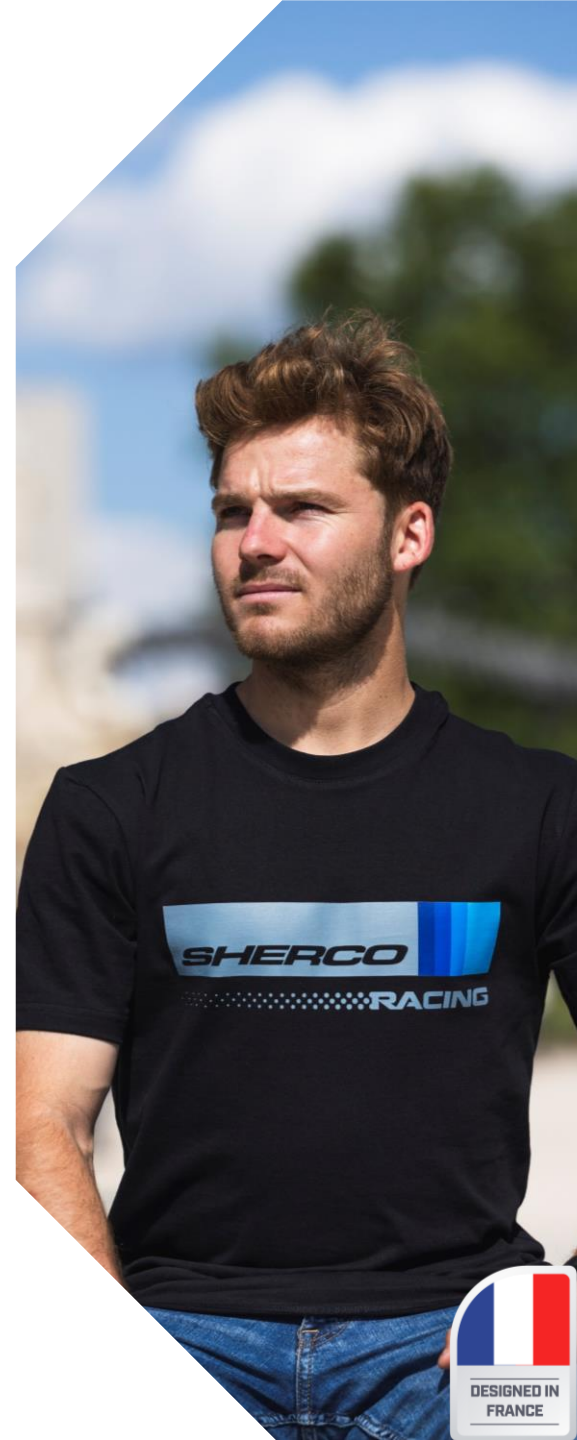

GOODIES

50 PRODUCTS



RACING PARTS & ACCESSORIES

350 PRODUCTS



SHERCO

PROMOTION

SALES SOLUTION SERVICES

- Sherco Academy France, Spain, Germany
Ambassador per Shop with special conditions
- Customer support on national races



SALES SOLUTION SERVICES

- Rental for ISDE since 2021



SHERCO

**RACING
FACTORY
TEAM**

RACE PROGRAM

- **ENDURO GP**
- **HARD ENDURO**
- **TRIAL GP**
- **RALLY RAID**

ENDURO FACTORY TEAM

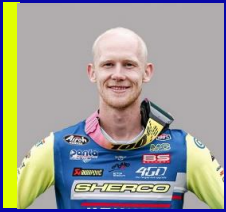

HAMISH MACDONALD – 300 SE

- 2019 YOUTH 125CC ENDURO GP WORLD CHAMPION
- 2020 JUNIOR ENDURO GP WORLD CHAMPION
- 2023 3RD E2 WORLD CHAMPIONSHIP
- 2024 P3 STANDINGS E3 WORLD ENDURO CHAMPIONSHIP



ANTOINE MAGAIN – 300 SE

- 2020 & 2023 E3 FRENCH ENDURO CHAMPION
- 2022 E1 SPANISH ENDURO CHAMPION
- 2023 3RD E3 CLASS WORLD CHAMPIONSHIP
- 2024 P1 STANDINGS E3 SPANISH CHAMPIONSHIP



WIL RUPRECHT – 300 SEF

- 2022 E2 WORLD ENDURO CHAMPION



JULIEN ROUSSALY – 300 SE

- 2023 3RD TROPHY TEAM ISDE ARGENTINA
- 2024 P1 STANDINGS OF THE FRENCH ENDURO CHAMPIONSHIP
- 2024 P5 STANDINGS E3 WORLD CHAMPIONSHIP
- 2024 PORTUGUESE CHAMPION



JEREMY SYDOW – 250 SE

- 2023 J2 FRENCH ENDURO CHAMPION
- 2023 2ND JUNIOR1 WORLD CHAMPIONSHIP, 3RD JUNIOR OVERALL
- 2024 LEADER OF THE GERMAN CHAMPIONSHIP



ZACHARY PICHON – 250 SE

- 2022 JUNIOR ENDUROGP CHAMPION
- 2022 JUNIOR OPEN SPANISH CHAMPION
- 2023 E2 SPANISH CHAMPION
- 2024 P4 STANDINGS E2 WORLD CHAMPIONSHIP
- 2024 P1 STANDINGS FRENCH ENDURO CHAMPIONSHIP

2024 ENDUROGP RACING PROGRAM

PORTUGAL
05/07 APRIL

PORTUGAL
12/14 APRIL

ROMANIA
10/12 MAY

ITALIA
21/23 JUNE

SLOVAKIA
12/14 JULY

WALES
2/4 AUGUST

FRANCE
13/15
SEPTEMBER

SHERCO

ENDURO RESULTS

- Enduro GP : World Champion Titles in EnduroGP / E2 / Junior / Youth
- Winner of :
 - Trèfle Lozérien AMV
 - Rand' Auvergne
 - Grappe de Cyrano
 - Aveyronnaise Classic
 - 12h of the Chinelle
 - Bassella Race



HARD ENDURO FACTORY TEAM



MARIO ROMAN

- SPANISH
- 17/01/1990
- BIKE: 300 SE



TEODOR KABAKCHIEV

- BULGARIAN
- 16/03/1998
- BIKE: 300 SE

2024 RACING PROGRAM



HARD ENDURO RESULTS

- Vice World Champion 2022
- USA Champion 2019
- 2 victories at the Romaniacs
- 4 victories at the Alestrem
- 4 victories at the Sea To Sky
- 2 victories at the Peyratoise
- 4 podiums at the Erzberg
- 6 victories at the Roof Of Africa
- 2 victories at the Red Bull Override (USA)
- 2024 : Teo Kabakchiev and Mario Roman, P2 and P3 at the opening round of the FIM Hard Enduro World Championship in England for the Hard Valleys Enduro / Mario Roman P3 at the Erzbzrg Rodeo, Teo Kabakchiev winner of the Bassela Race



SHERCO

TRIAL FACTORY TEAM



ADAM RAGA – TRIALGP

- 6 TIMES FIM TRIAL WORLD CHAMPION
- 8 TIMES TRIAL SPANISH CHAMPION
- P2 INDOOR DL12 2024
- P2 TRIAL GP JAPAN 2024
- 2024 P3 STANDIGS WORLD CHAMPIONSHIP



EMMA BRISTOW – TRIALGP WOMEN

- 9 TIMES TRIALGP WOMEN
- WINNER OF THE WOMEN CLASS SSOT 2024 (12 VICTORIES)



BENOIT BINCAZ – TRIALGP

- 2023 FRENCH CHAMPION



JACK PEACE – TRIAL 2

- 2023 UK TRIAL CHAMPION
- 2023 P2 FIM TRIAL WORLD CHAMPIONSHIP TRIAL 2
- 2024 P2 AT THE SSOT
- 2024 P2 STANDINGS WORLD CHAMPIONSHIP TRIAL 2



ARNAU FARRE – TRIAL 2

- 2023 WINNER OF THE "3 JOURS DE LA TRUYÈRES"
- 2022 P3 WORLD CHAMPIONSHIP TRIAL 2
- P1 OVERSEA RIDERS AT THE SSOT 2024
- 2024 P3 STANDINGS WORLS CHAMPIONSHIP TRIAL 2



ALEX CANALES – TRIAL 2

- 2021 TR2 SPANISH CHAMPION
- 2023 P8 FIM TRIAL2 WORLD CHAMPIONSHIP
- 2023 5TH IN THE 2023 TR1 SPANISH CHAMPIONSHIP
- 2024 P1 STANDINGS WORLS CHAMPIONSHIP TRIAL 2

JAPAN
17/19 MAY

ANDORRA
7/8 JUNE

ITALIA
14/16 JUNE

GERMANY
05/07 JULY

BELGIUM
13/14 JULY

FRANCE
24/25 AUGUST

SPAIN
13/15
SEPTEMBER

SHERCO

TRIAL RESULTS

AWARDS

- 2024 : P2 at the DL12, P2 at the opening round of the Trial GP
- 2023 : 2 World Champion Titles, 1 European Title, 7 National Titles*
- 9 World Woman Trial GP Titles for Emma Bristow
- 12 victories at the SSDT in womens class for Emma Bristow
- 50 victories in Trial



* Sherco and Scorpa



SHERCO

TRIAL FACTORY TEAM

WINNER 2024



P1 : JACK PRICE

P2 : JACK PEACE

P5 : DAN PEACE

P1 OVERSEA RIDER : ARNAU FARRE

P2 125 CC : HARRY TURNER

P1 WOMEN : EMMA BRISTOW



SHERCO

RALLY RAID FACTORY TEAM



LORENZO SANTOLINO

- SPANISH
- 04/08/1987
- BIKE: 450 SEF RALLY
- CLASS: RALLY GP



HARITH NOAH

- INDIAN
- 29/01/1993
- BIKE: 450 SEF RALLY
- CLASS: RALLY 2

2024 RACING PROGRAM

DAKAR

5-19 JANUARY

BP ULTIMATE RALLY-
RAID
2-7 APRIL

BAJA ARAGON

26-28 JULY

MOROCCO

05/11 OCTOBER

SHERCO

RALLY RAID FACTORY TEAM



WINNER

DAKAR RALLY 2 HARITH NOAH



2024



RALLY RAID FACTORY TEAM

- Winner of the Rally 2 Class at the Dakar Rally 2024
- Winner of several stages at the Dakar Rally
- 6th overall Dakar Rally 2021
- 2nd at the Andalousia Rally 2021
- 3rd at the Andalousia Rally 2020
- Winer of the Aragon Baja
- Winner of the India Baja
- Winner of the Sardinia Rally
- Winner of the Baja Extremadura
- Rally World Champion 2010



SHERCO

**2025
ENDURO
NEW RANGE**

ENDURO
FACTORY

COMMON IMPROVEMENTS ENDURO FACTORY

2T STROKE

125 SE

250
300 SE

4T STROKE

250
300 SEF

450
500 SEF



SHERCO

BODYWORK

- New bodywork, featuring new in-mold graphics on the radiator and side panels
- New LED taillight



FULL RANGE

SHERCO

AIR FILTER



- New air filter box improving engine efficiency
- Easier and quicker side access to the filter
- Possibility to change the air filter without tools



FULL RANGE

SHERCO



SELLE DALLA VALLE
ITALY

SE 300

SE 300

FRAME



- **New chassis: weight reduction of 250g**
- **New engine lower tube geometry**
- **New steering pipe: weight savings and improved comfort**

FRAME

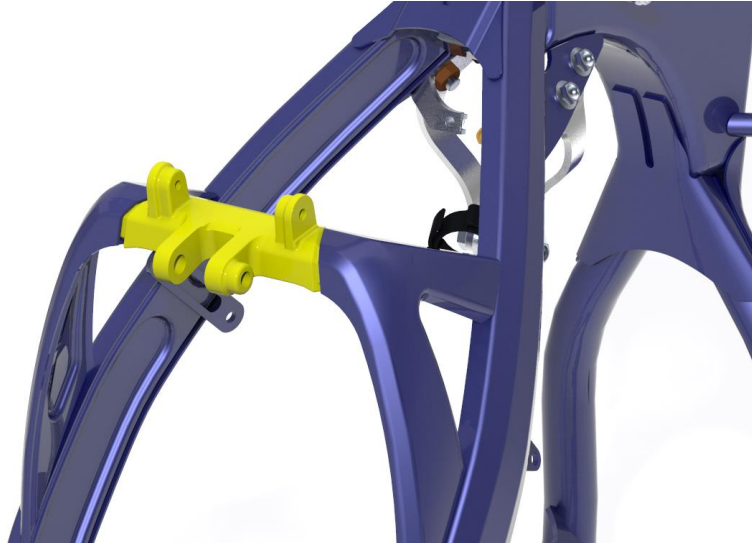

- Forged shock absorber arch
- New steering lock on the steering axle
- New lower chain guide for reduced noise and weight



FULL RANGE

SHERCO

FRAME

- New aluminum rear subframe, weight reduction of 254 g



FULL RANGE

SHERCO

COOLING SYSTEM

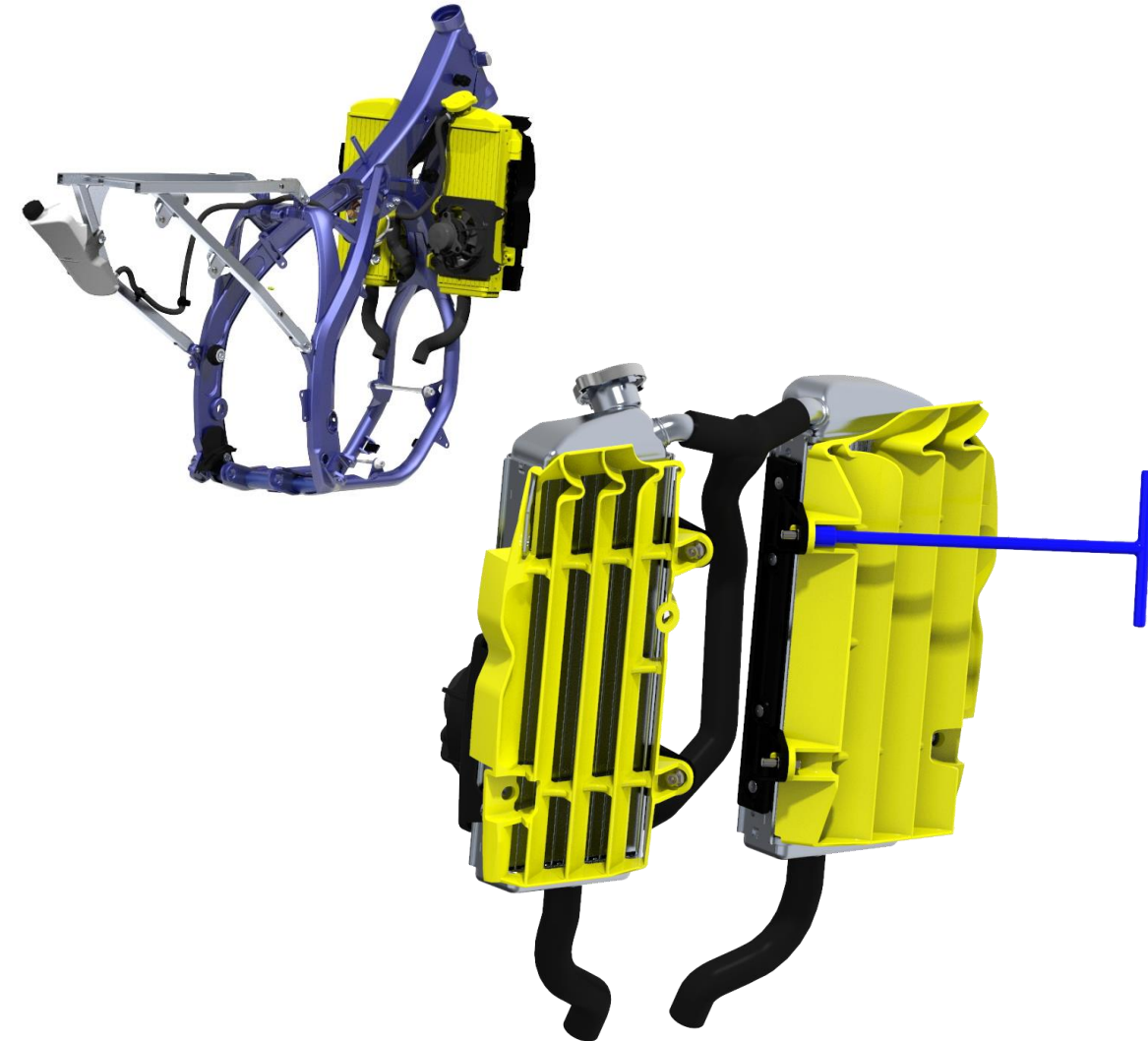

- New radiators, 157g lighter
- 15% more cooling efficiency
- Radiator grilles improving rigidity and airflow
- Silicone hoses
- New expansion tank more compact
- New fan, more compact, lighter, easier to remove

BODYWORK

- New frame protectors with anti slip feature
- New rear taillight support, providing better grip on the rear of the motorcycle when lifting it



FULL RANGE

SHERCO

BRAKING DISCS



- New front and rear brake discs
- Increased braking power

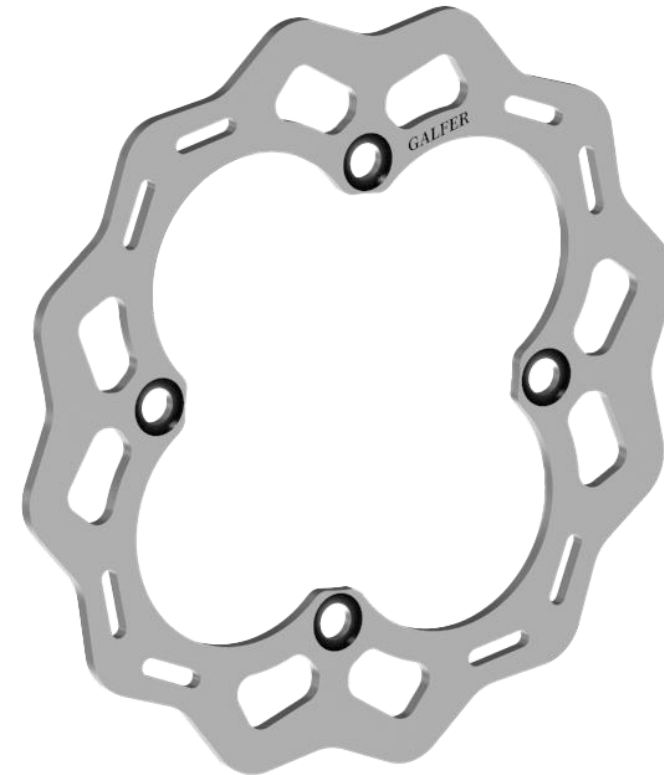

FULL RANGE

SHERCO

TRIPLE CLAMPS

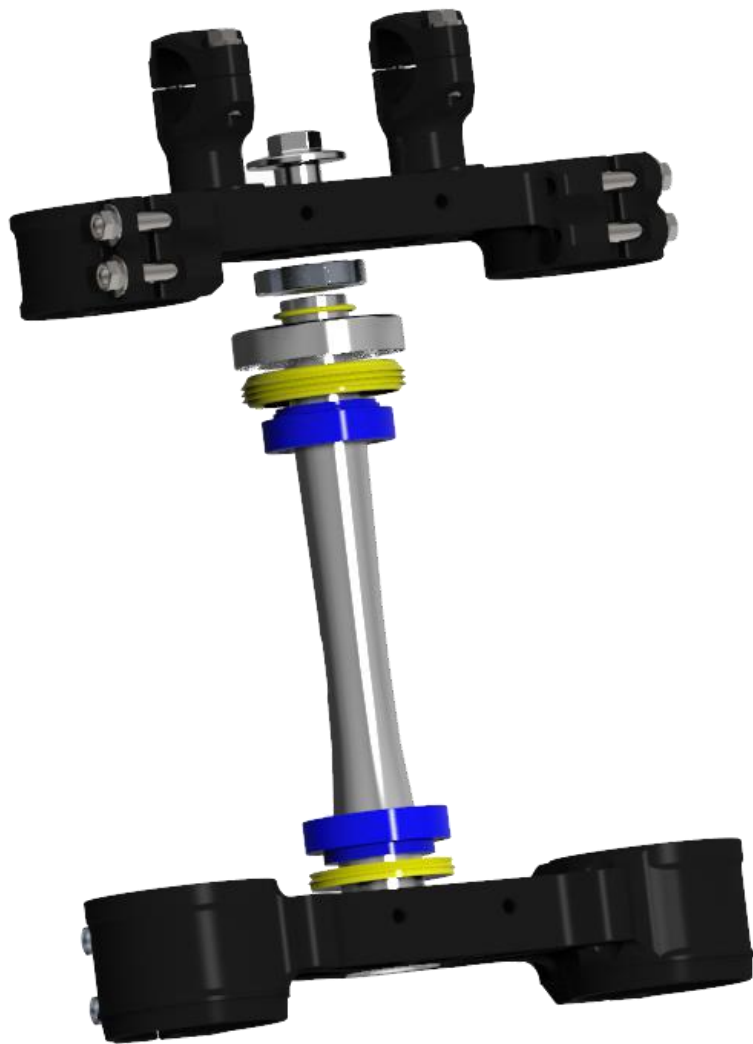

- New 7075 CNC triple clamps
- New steering column: better front-wheel comfort and 150g weight reduction
- Improved bearing sealing
- New handlebar position +5mm

DASHBOARD SUPPORT



- New position of the dashboard for improved visibility
- Dampening of the dashboard on two axis and improvement of the wiring layout behind the headlight



FULL RANGE

SHERCO

ENGINE AXES

- New lighter engine mounting axes



FULL RANGE

SHERCO

PROTECTIONS

- New larger handguards for better protection, new fork protectors

- New fork protectors, improved protection of the tubes and more space for 90-100/21 tires



FULL RANGE

SHERCO

PROTECTIONS

- New engine skid plate

- Improved accessibility to the mounting screws for ease of disassembly



FULL RANGE

SHERCO

SIDE STAND

■ New side stand



FULL RANGE

SHERCO

ELECTRICAL HARNESS



- New lighter wiring harness by 210g
- New layout of electrical components at the rear of the motorcycle to improve accessibility
- Accessibility of the OBD connector through the airbox access panel
- Improved ergonomics of the wiring harness routing on the motorcycle

FUEL TANK DAMPER

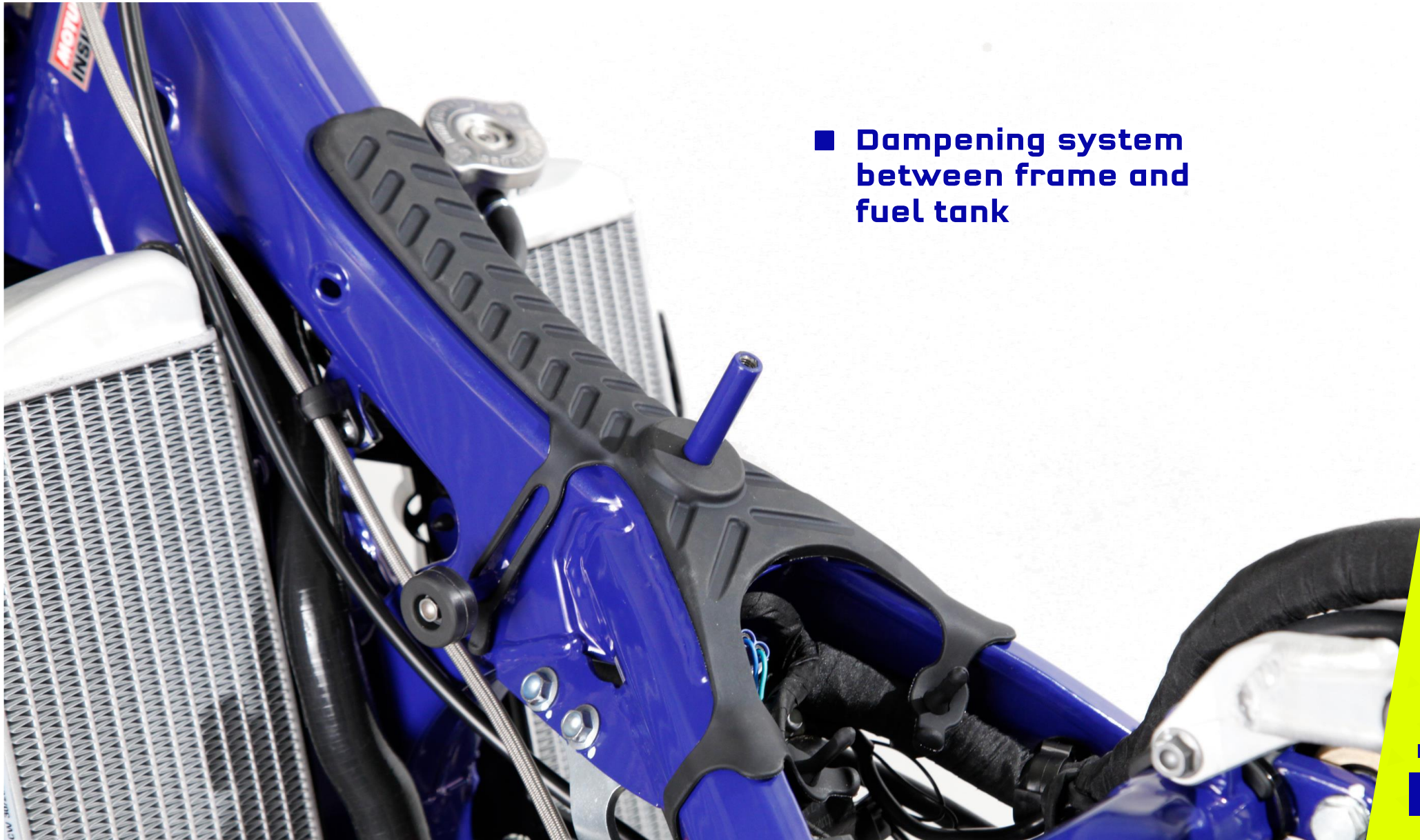

- Dampening system between frame and fuel tank

FULL RANGE

SHERCO

LINKAGE AXLES

- Lighter linkage axle, shock comfort has been improved



- Flat-sided axle for ease of assembly/disassembly

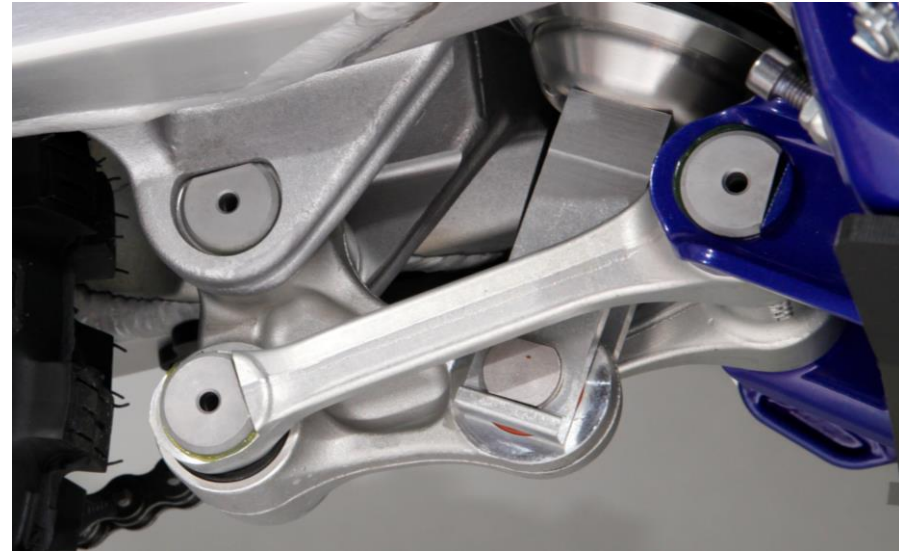

MUFFLER

- Accessibility and disassembly of the muffler simplified



FULL RANGE

SHERCO

SPECIFIC IMPROVEMENTS

2T STROKE

125^{SE}

250
300^{SE}



FUEL TAP

- Modification of the fuel tap position for easier access



2T STROKE

125^{SE}

250
300^{SE}

SHERCO

SPECIFIC IMPROVEMENTS



2T STROKE

250
300 SE

EXHAUST

- New exhaust pipe increasing ground clearance



2T STROKE

250
300^{SE}

SHERCO

SPECIFIC IMPROVEMENTS

2T STROKE

250 SE



GEARBOX

- New gearbox manufactured in Nîmes (France) and tested in competition: modification of gears ratios 3 to 5

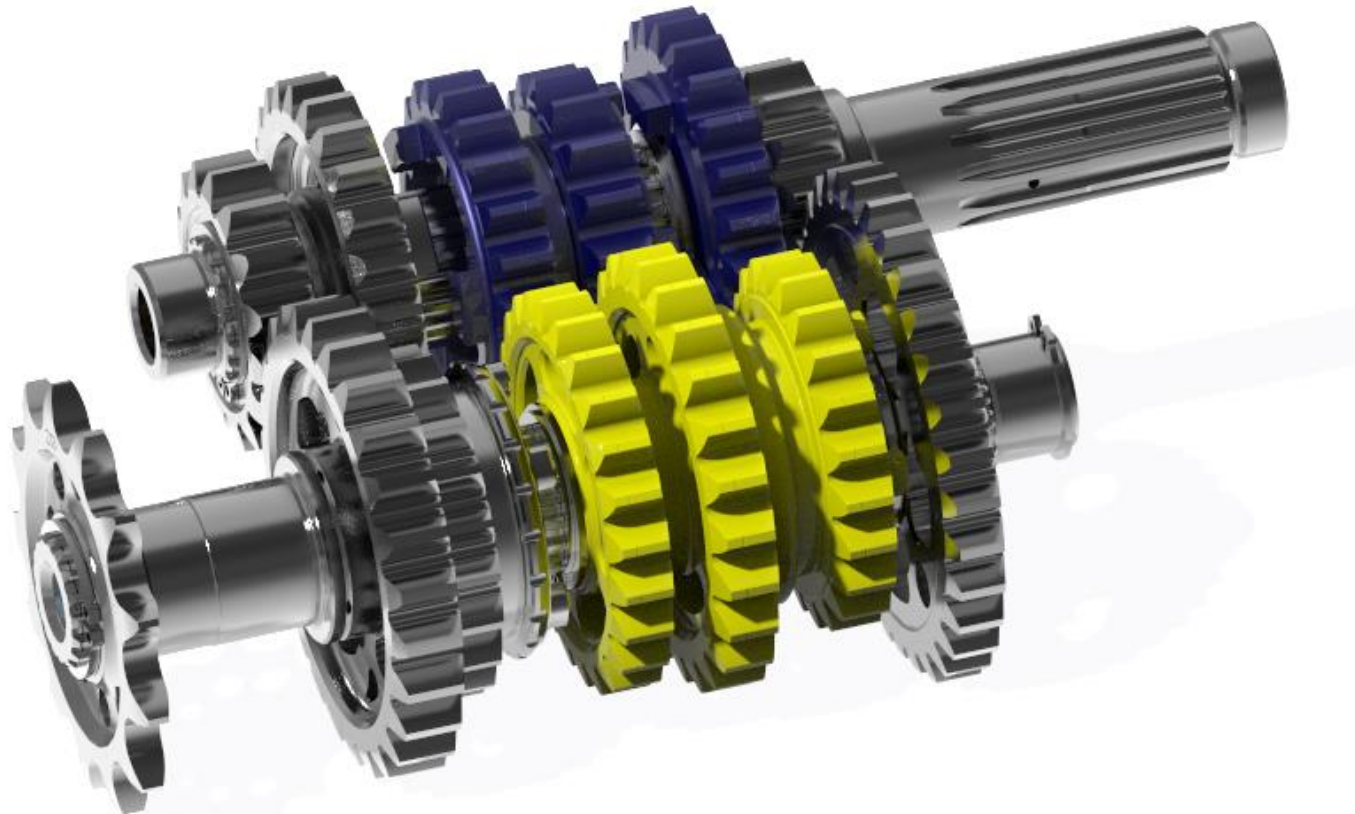

2T STROKE

250_{SE}

SHERCO

SPECIFIC IMPROVEMENTS



4T STROKE

250
300 SEF

4T STROKE

450
500 SEF

EXHAUST



- New Akrapovic full exhaust system
- Performance enhancement
- Noise reduction that is compliant with new FIM standards



4T STROKE

250
300_{SEF}

450
500_{SEF}

SHERCO

FUEL PUMP

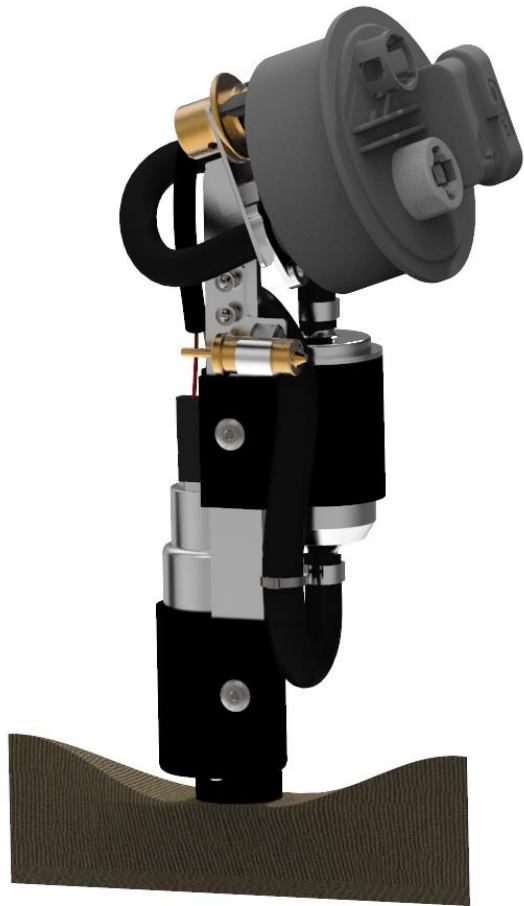

2024

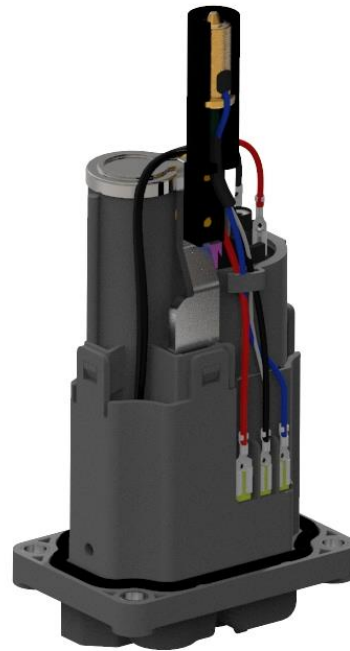

2025

- New more compact fuel pump: 200g lighter
- Optimization of fuel pressure regulation

4T STROKE

250
300_{SEF}

450
500_{SEF}

SHERCO

SPECIFIC IMPROVEMENTS

4T STROKE

250
300
SEF



CYLINDER HEAD

- Lightened and reinforced camshaft bearing support to allow higher revs
- Increase of the rev limiter from 13,700 to 14,000 RPM



2024



2025

4T STROKE

250
300_{SEF}

SHERCO

SPECIFIC IMPROVEMENTS

4T STROKE

450
500 SEF



SWINGARM



- New design and technology
- Weight savings of 360 grams
- Improved riding comfort, traction, new bearing and sealing system, new graduations to facilitate chain tension adjustment



4T STROKE

450
500_{SEF}

SHERCO

FRONT WHEEL



- New front wheel: spokes, axles, hubs
- Redesigned hubs to improve stiffness and reduce unsprung weight, new spacer system with mud-resistant flanges
- Total weight savings: 650 gr

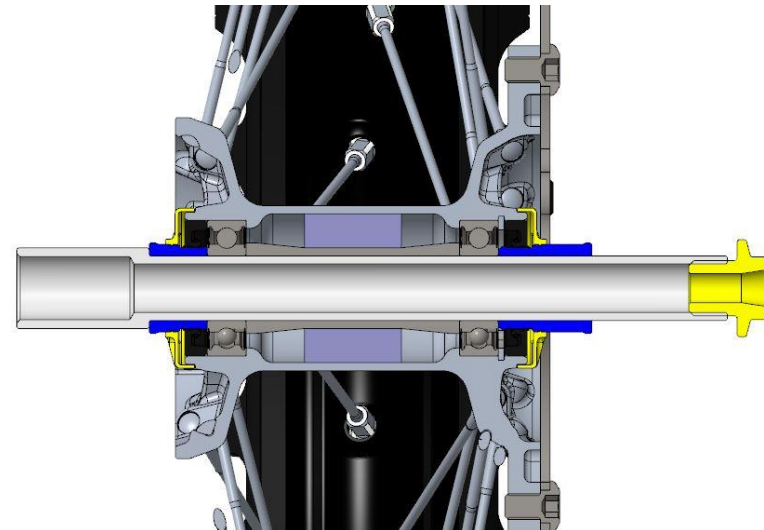

4T STROKE

450
500_{SEF}

SHERCO

REAR WHEEL



- New rear wheel: spokes, axles, hubs
- Redesigned hubs to improve stiffness and reduce unsprung weight, new spacer system with mud-resistant flanges
- Weight savings: 310 gr

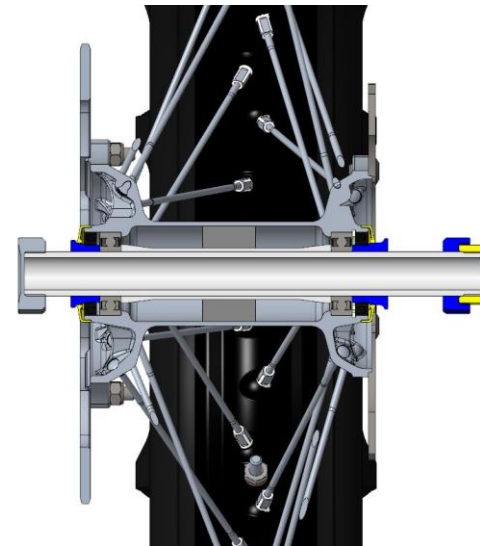

4T STROKE

450
500_{SEF}

SHERCO

TILT SENSOR



- Integration of the tilt sensor, cuts off the engine in case of a fall



4T STROKE

450
500_{SEF}

SHERCO

SUMMARY

SHERCO
FACTORY

What is new ?	2 stroke			4 stroke			
	125 SE	250 SE	300 SE	250 SEF	300 SEF	450 SEF	500 SEF
2025 design	x	x	x	x	x	x	x
New air filter box	x	x	x	x	x	x	x
New chassis	x	x	x	x	x	x	x
New cooling system	x	x	x	x	x	x	x
New braking discs	x	x	x	x	x	x	x
New CNC tiple clamps	x	x	x	x	x	x	x
New dashboard support	x	x	x	x	x	x	x
New handguards	x	x	x	x	x	x	x
New fork protector	x	x	x	x	x	x	x
New skid plate	x	x	x	x	x	x	x
New side stand	x	x	x	x	x	x	x
New electrical harness	x	x	x	x	x	x	x
New fuel tank mount	x	x	x	x	x	x	x
New linkages axles	x	x	x	x	x	x	x
Improved accessibilty to the muffler	x	x	x	x	x	x	x
Modification of the fuel tap position	x	x	x				
New exhaust pipe		x	x				
New gearbox		x					
New Akrapovic full exhaust system				x	x	x	x
New fuel pump				x	x	x	x
New map				x	x	x	x
New cylinder head				x	x		
New swingarm						x	x
New front and rear wheels						x	x
Tilt sensor						x	x

ENDURO
RACING

300 SE / 300 SEF RACING RANGE

2T STROKE



4T STROKE



300 SE / 300 SEF RACING RANGE

Points of differentiation from the Factory range:

- Racing Decal Kit
- KYB 48mm open-cartridge fork
- Forged triple clamps
- New handlebar
- Monobloc swingarm
- Racing front and rear brake discs
- Halogene headlight plate
- MITAS tires
- SPES exhaust system (4 Stroke)



MOTORBIKES COMPONENTS

2 STROKE COMPARISON

COMPONENTS	SHERCO FACTORY	COMPETITOR	SHERCO RACING
FRONT SUSPENSION CLOSED CARTRIDGE	✓	✓	✗
SPES EXHAUST	✓	✗	✓
FAN + WATER TANK	✓	✗	✗
ENGINE SKID PLATE	✓	✗	✗
EXCEL TAKASAGO RIMS	✓	✗	✓
MICHELIN TIRES	✓	✗	✗
TRIPLE CLAMP CNC	✓	✗	✗

4 STROKE COMPARISON

COMPONENTS	SHERCO FACTORY	COMPETITOR	SHERCO RACING
FRONT SUSPENSION CLOSED CARTRIDGE	✓	✓	✗
AKRAPOVIC EXHAUST	✓	✗	✗
FAN + WATER TANK	✓	✗	✗
ENGINE SKID PLATE	✓	✗	✗
EXCEL TAKASAGO RIMS	✓	✗	✓
MICHELIN TIRES	✓	✗	✗
TRIPLE CLAMP CNC	✓	✗	✗

SHERCO

PARTNERS

PARTNERS

ENDURO



TRIAL



RALLY RAID



SHERCO

THE END



[SHERCO.COM](https://www.sherco.com)

SHERCO recommends **MOTUL**

SHERCO pictures, the company reserves the right, in order to improve its services, to change specifications and dimensions without prior notice. Pictures are not copy-written. There may be typographical errors in this literature. Pictures were taken abroad on private land. Photos © - J.M Pouget / M. Font / MR. Sprang / F. Paul Creation & realisation

MGT

